

Erlangen Regional
Computing Center



Efficient parallel programming on ccNUMA nodes

Performance characteristics of ccNUMA nodes

First touch placement policy

- ccNUMA:
 - Whole memory is **transparently accessible** by all processors
 - but **physically distributed** across multiple locality domains (LDs)
 - with **varying bandwidth and latency**
 - and **potential contention** (shared memory paths)
- How do we make sure that memory access is always as "local" and "distributed" as possible?

Note: Page placement is implemented in units of OS pages (often 4kB, possibly more)

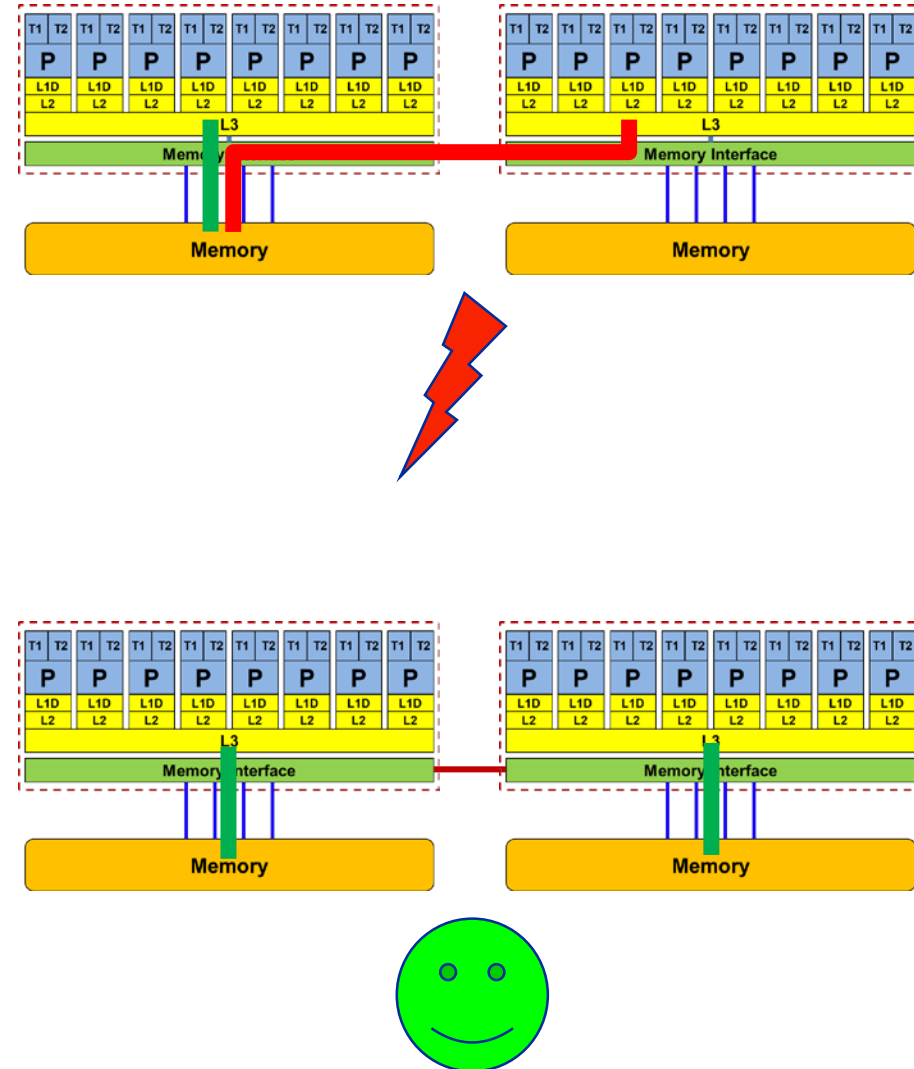

How much does nonlocal access cost?

Example: AMD “Epyc” 2-socket system

(8 chips, 2 sockets, 48 cores):

STREAM Triad bandwidth measurements [Gbyte/s]

CPU node	0	1	2	3	4	5	6	7
MEM node 0	32.4	21.4	21.8	21.9	10.6	10.6	10.7	10.8
1	21.5	32.4	21.9	21.9	10.6	10.5	10.7	10.6
2	21.8	21.9	32.4	21.5	10.6	10.6	10.8	10.7
3	21.9	21.9	21.5	32.4	10.6	10.6	10.6	10.7
4	10.6	10.7	10.6	10.6	32.4	21.4	21.9	21.9
5	10.6	10.6	10.6	10.6	21.4	32.4	21.9	21.9
6	10.6	10.7	10.6	10.6	21.9	21.9	32.3	21.4
7	10.7	10.6	10.6	10.6	21.9	21.9	21.4	32.5

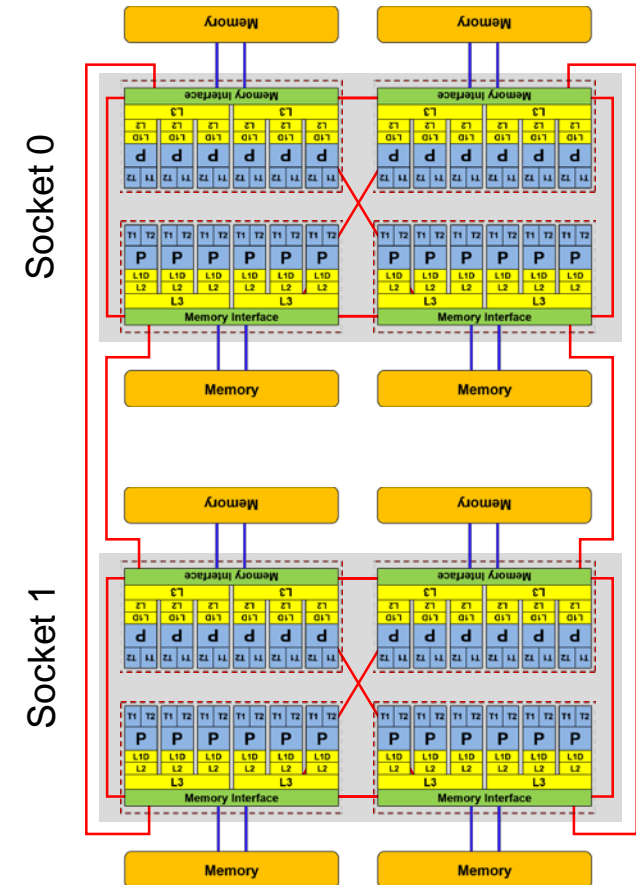

numactl as a simple ccNUMA locality tool :

How do we enforce some locality of access?

- **numactl** can influence the way a binary maps its memory pages:

```
numactl --membind=<nodes> a.out      # map pages only on <nodes>
      --preferred=<node> a.out      # map pages on <node>
                                       # and others if <node> is full
      --interleave=<nodes> a.out    # map pages round robin across
                                       # all <nodes>
```

- Examples:

```
for m in `seq 0 7`; do
  for c in `seq 0 7`; do
    env OMP_NUM_THREADS=6 \
      numactl --membind=$m likwid-pin -c M${c}:0-5 ./stream
  done
done
```

ccNUMA map scan
for EPYC system

```
numactl --interleave=0-7 likwid-pin -c E:N:8:1:12 ./stream
```

- But what is the default without **numactl**?

"Golden Rule" of ccNUMA:

A memory page gets mapped into the local memory of the processor that first touches it!

(Except if there is not enough local memory available)

- **Caveat:** “to touch” means “to write,” not “to allocate”
- Example:

```
double *huge = (double*)malloc(N*sizeof(double));  
  
for(i=0; i<N; i++) // or i+=PAGE_SIZE/sizeof(double)  
    huge[i] = 0.0;
```

Memory not mapped here yet

Mapping takes place here

- It is sufficient to touch a single item to map the entire page

Most simple case: explicit initialization

```
integer,parameter :: N=10000000  
double precision A(N), B(N)
```

```
A=0.d0
```



```
!$OMP parallel do  
do i = 1, N  
    B(i) = function ( A(i) )  
end do  
!$OMP end parallel do
```

```
integer,parameter :: N=10000000  
double precision A(N),B(N)
```

```
!$OMP parallel  
!$OMP do schedule(static)
```

```
do i = 1, N
```

```
    A(i)=0.d0
```

```
end do
```

```
!$OMP end do
```

```
...
```

```
!$OMP do schedule(static)
```

```
do i = 1, N
```

```
    B(i) = function ( A(i) )
```

```
end do
```

```
!$OMP end do
```

```
!$OMP end parallel
```



- Required condition: OpenMP **loop schedule** of initialization must be the same as in all computational loops
 - Only choice: **static!** Specify **explicitly** on all NUMA-sensitive loops, just to be sure...
 - Imposes some constraints on possible optimizations (e.g. load balancing)
 - Presupposes that all **worksharing loops** with the **same loop length** have the **same thread-chunk mapping**
 - If **dynamic scheduling/tasking** is unavoidable, the problem cannot be solved completely if a team of threads spans more than one LD
 - Static parallel first touch is still a good idea
 - OpenMP 5.0 will have rudimentary memory affinity functionality
- How about **global objects**?
 - If communication vs. computation is favorable, might consider **properly placed copies** of global data
- C++: Arrays of objects and `std::vector<>` are by default initialized sequentially
 - **STL allocators** provide an elegant solution

- Bad locality **limits scalability** (whenever a ccNUMA node boundary is crossed)
 - Just an indication, not a proof yet
- Running with **numactl --interleave** might give you a hint
- Consider using performance counters
 - **LIKWID-perfctr** can be used to measure nonlocal memory accesses
 - Example for Intel dual-socket system (IvyBridge, 2x10-core):

```
likwid-perfctr -g NUMA -C  
M0:0-4@M1:0-4 ./a.out
```

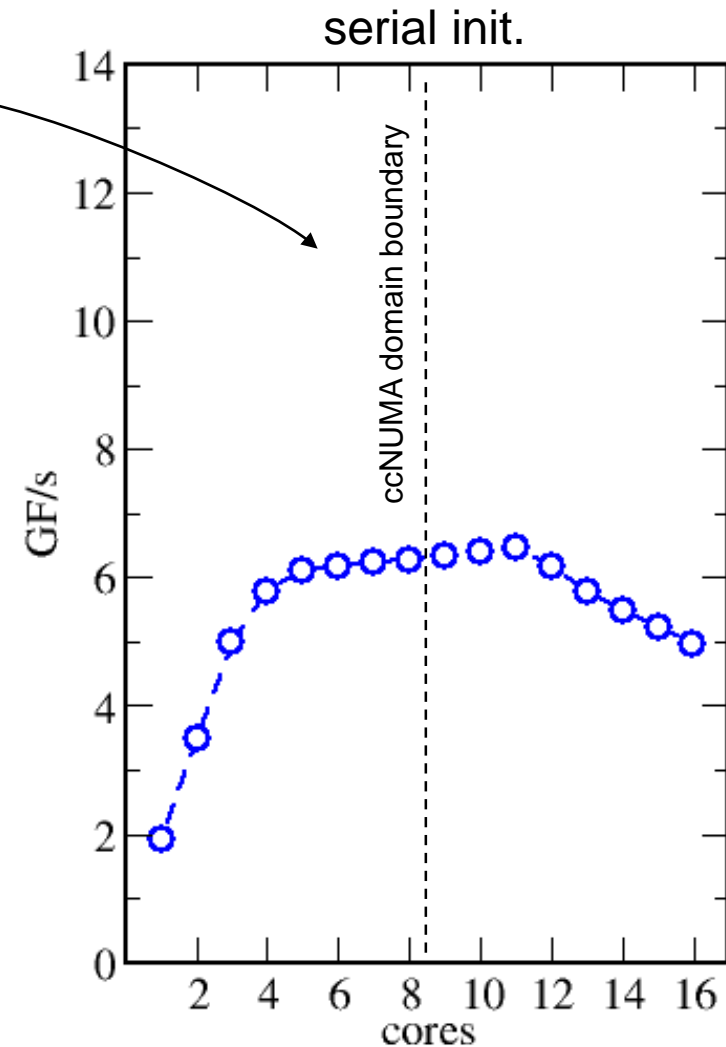

- Intel Ivy Bridge EP node (running 2x5 threads):
measure NUMA traffic per core

```
likwid-perfctr -g NUMA -C M0:0-4@M1:0-4 ./a.out
```

- Summary output:

Metric	Sum	Min	Max	Avg
Runtime (RDTSC) [s] STAT	4.050483	0.4050483	0.4050483	0.4050483
Runtime unhalted [s] STAT	3.03537	0.3026072	0.3043367	0.303537
Clock [MHz] STAT	32996.94	3299.692	3299.696	3299.694
CPI STAT	40.3212	3.702072	4.244213	4.03212
Local DRAM data volume [GByte] STAT	7.752933632	0.735579264	0.823551488	0.7752933632
Local DRAM bandwidth [MByte/s] STAT	19140.761	1816.028	2033.218	1914.0761
Remote DRAM data volume [GByte] STAT	9.16628352	0.86682464	0.957811776	0.916628352
Remote DRAM bandwidth [MByte/s] STAT	22630.098	2140.052	2364.685	2263.0098
Memory data volume [GByte] STAT	16.919217152	1.690376128	1.69339104	1.6919217152
Memory bandwidth [MByte/s] STAT	41770.861	4173.27	4180.714	4177.0861

- Caveat:** NUMA metrics vary strongly between CPU models

About half of the overall memory traffic is caused by the remote domain!

OpenMP STREAM triad on a dual AMD Epyc 7451 (6 cores per LD)

- **Parallel init:** Correct parallel initialization
- **LD0:** Force data into LD0 via `numactl -m 0`
- **Interleaved:** `numactl --interleave <LD range>`

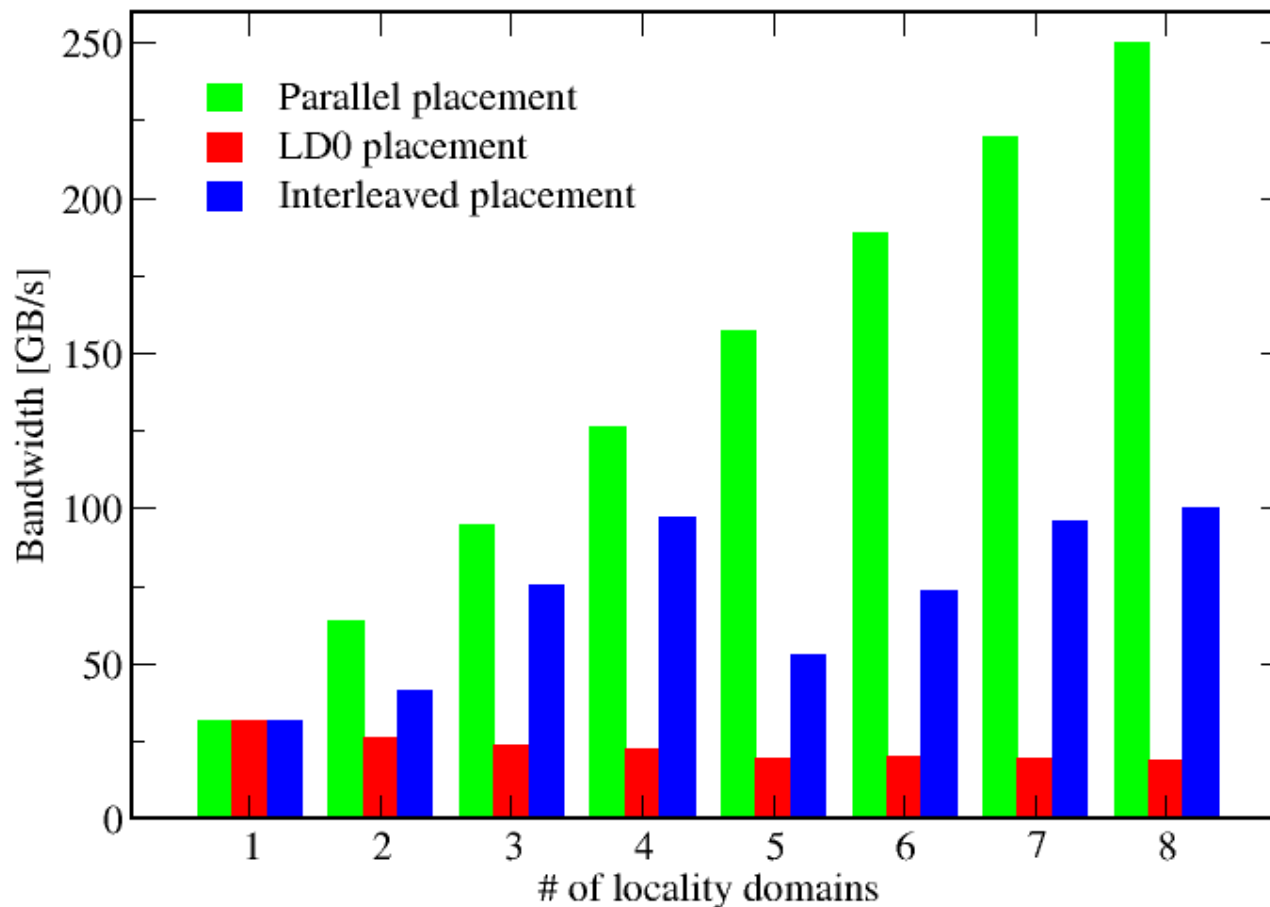

- **Identify the problem**
 - Is ccNUMA an issue in your code?
 - Simple test: run with `numactl --interleave`
- **Apply first-touch placement**
 - Look at initialization loops
 - Consider loop lengths and static scheduling
 - C++ and global/static objects may require special care
- **NUMA balancing is active on many Linux systems today**
 - Automatic page migration
 - Slow process, may take many seconds (configurable)
 - Not a silver bullet
 - Still a good idea to do parallel first touch
- **If dynamic scheduling cannot be avoided**
 - Consider round-robin placement as a quick (but non-ideal) fix
 - OpenMP 5.0 will have some data affinity support